

ESH K

Mobile Radgreiferhebeanlage mit kurzen Hub
Mobile column Lift with short stroke



IME-AUTOLIFT

Autolift GmbH



...so easy to move

Technische Daten/technical data

	ESH K 1521/1000	ESH K 3041/1000
Tragkraft/capacity	2 x 7,5 t = 15 t	4 x 7,5 t = 15 t
Hubhöhe/lifting height	900 mm	900 mm
Reifengröße/tyre size	870 – 1080, 18 – 24 Zoll	870 – 1080, 18 – 24 Zoll
Hubzeit/lifting time	ca. 95 sec	ca. 95 sec
Strombedarf/power	3 x 400, 230 V	3 x 400, 230 V
Motor/motor	2,2 KW pro Säule/per column	2,2 KW pro Säule/per column
Abmessungen/dimensions	1090 x 980 x 1950 mm	1090 x 980 x 1950 mm
Gewicht/weight	380 kg pro Säule/per column	380 kg pro Säule/per column



IME-AUTOLIFT

Autolift GmbH

Mit der Radgreiferhebeanlage ESH K 1521/1000 können LKW und Busse an einer Achse 900 mm hochgehoben werden. Diese ermöglicht bereits eine gute Arbeitshöhe unter dem Motor oder an den Achsen.

Durch Verwendung von mobilen Unterstellböcken wird auch radfreies heben für Bremsarbeiten ermöglicht.

Mit der Radgreiferhebeanlage ESH K 3041/1000 kann das komplette Fahrzeug auf 900 mm Höhe hochgehoben werden.

With the mobile column lift ESH K 1521/1000 trucks or busses can be lifted on one axle 900 mm high. This enables a good working height for repairs. Wheel free lifting is possible for repairs of the brakes .

With the column lift ESH K 3041/1000 the complete vehicle can be lifted to a height of 900 mm.

Zubehör/options



Hydraulisches Fahrwerk
hydraulic trolley



Trailer Traverse
trailer traverse



Unterstellböcke
axle stands



Armtraverse
armtraverse



Verstellbare Radgabel
adjustable forks



Pkw-Adapter
small wheel adapter

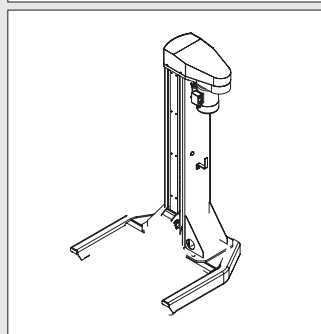
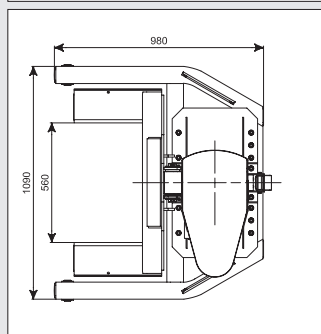
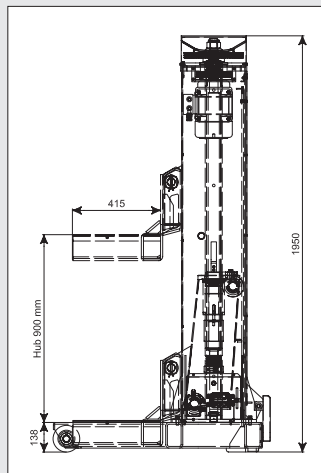

Autolift GmbH

Mayrwiesstraße 16
5300 Hallwang/Salzburg
Tel.: +43 662 - 45 05 88
Fax: +43 662 - 45 05 88 - 18
Mail: office@autolift.info
Web: www.autolift.info